

ULTRA HIGH PRESSURE

Proteus PTO

PRODUCT SPECIFICATION

A self contained unit that can slip on most trucks (1 ton or higher) equipped with a PTO. Command Skid Units are designed for rapid fire attack with installation on any Type 6, brush truck, rapid response, or other appropriately configured PTO capable vehicle. This unit is ideal for fuel fires, forest and wild-land fires, and structure fires. Tank options are available.



PRODUCT SPECIFICATIONS

	20 GPM
Flow	20 GPM (76 LPM)
Pump Pressure	1450 PSI (100 bar)
Nozzle Pressure	1250 PSI (86 bar)
Weight (pump)	300 lbs (136 kg)
Height	40 in. (102 cm)
Width	43.25 in. (110 cm)
Depth	30.5 in. (77.5 cm)

PRODUCT FEATURES

- ✓ Water and Foam Skid Unit
- ✓ Water and Foam Gauges
- ✓ Auto Water Tender
- ✓ Front Panel Foam Fill
- ✓ Pressure Gauge
- ✓ 1.5" Front Panel Water Inlet
- ✓ 0% - 6% Foam Proportioner
- ✓ 200' 3/4" UHP Hose
- ✓ Elkhart Chief UHP Nozzle
- ✓ Venturi Foam System
- ✓ 1 Year Limited Warranty
- ✓ Auto / Manual Modes
- ✓ Harrison Hydra-Qube Sr.

Nozzle Options



Elkhart Chief Nozzle



Udor Wildland Nozzle

POINT OF CONTACT:
Matt Cowden
Director of Sales and Marketing

P: (352) 320-6017
E: sales@pyrohma.com
W: www.pyrohma.com

495 Oak Road
Ocala, FL,
United States

ESD Fire

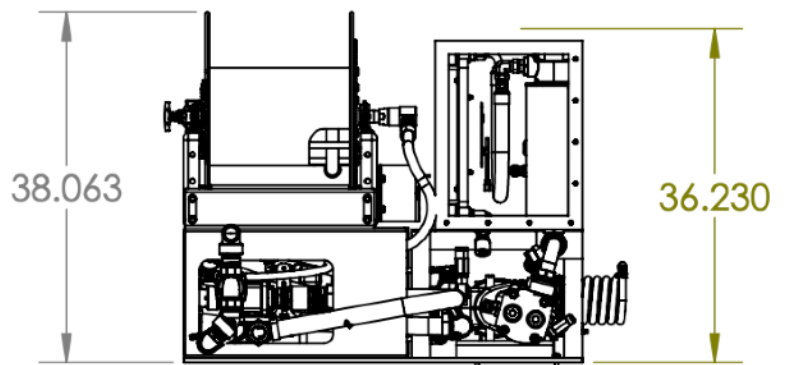
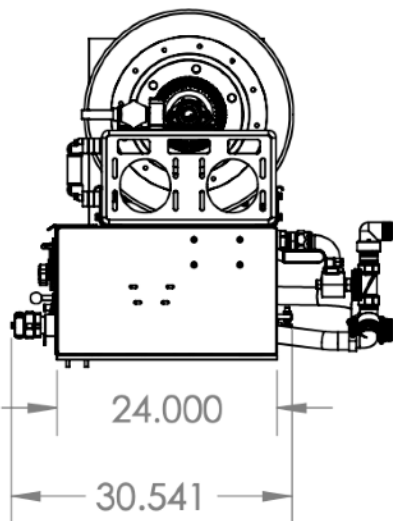
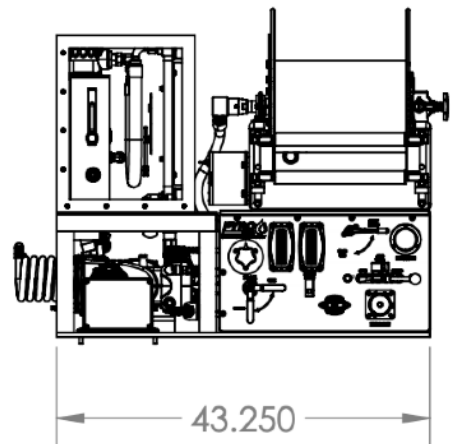
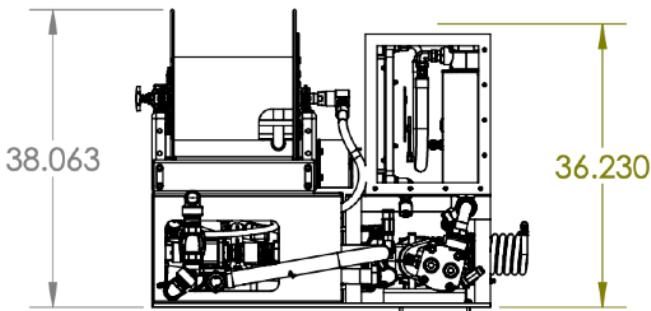
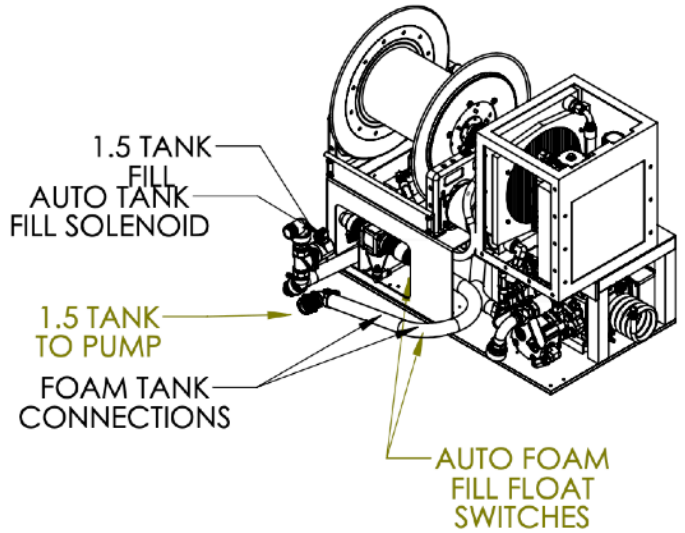
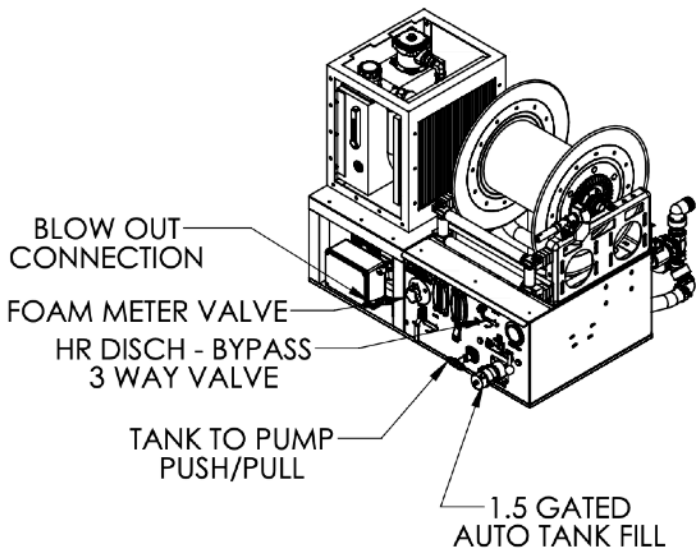

POINT OF CONTACT:
 Matt Cowden
 Director of Sales and Marketing

P: (352) 320-6017
 E: sales@pyrohma.com
 W: www.pyrohma.com

495 Oak Road
 Ocala, FL,
 United States