

ULTRA HIGH PRESSURE COMMAND

PRODUCT SPECIFICATION

A workhorse of the UHP family. A self contained unit that can slip on most trucks (1/2 ton or higher). Command Skid Units are designed for rapid fire attack with easy installation on any Type 6, brush truck, rapid response, or other appropriately configured command vehicle. These products are ideal for fuel fires, forest and wild-land fires, and structure fires. These self-contained units incorporate a state- of-the-art UHP fire suppression system powered by a gasoline or diesel engine.

PRODUCT SPECIFICATIONS

	10 GPM GAS	20 GPM GAS	20 GPM DIESEL
Flow	10 GPM (38 LPM)	20 GPM (76 LPM)	20 GPM (76 LPM)
Pump Pressure	1450 PSI (100 bar)	1450 PSI (100 bar)	1450 PSI (100 bar)
Nozzle Pressure	1250 PSI (86 bar)	1250 PSI (86 bar)	1250 PSI (86 bar)
Weight (pump)	250 lbs (** kg)	300 lbs (** kg)	400 lbs (** kg)
Height	40 in.(102 cm)	40 in.(102 cm)	40 in.(102 cm)
Width	48 in. (122 cm)	48 in. (122 cm)	48 in. (122 cm)
Depth	37 in. (94 cm)	37 in. (94 cm)	37 in. (94 cm)

PRODUCT FEATURES

- ✓ Water and Foam Skid Unit
- ✓ Water and Foam Gauges
- ✓ Auto Water Tender
- ✓ Front Panel Foam Fill
- ✓ Pressure Gauge
- ✓ 1.5" Front Panel Water Inlet
- ✓ 0% - 6% Foam Proportioner
- ✓ 200' 3/4" UHP Hose
- ✓ Elkhart Chief UHP Nozzle
- ✓ Venturi Foam System
- ✓ 1 Year Limited Warranty
- ✓ Auto / Manual Modes
- ✓ On Board Fuel Cell and Battery
- ✓ Kohler 26 HP Fuel Injected **Gas** Engine
- ✓ Kubota DH 902 **Diesel** Engine

Nozzle Options



Elkhart Chief Nozzle



Udor Wildland Nozzle

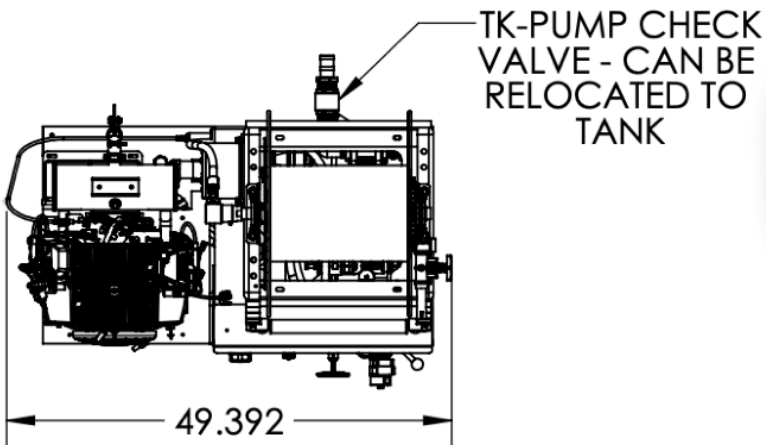
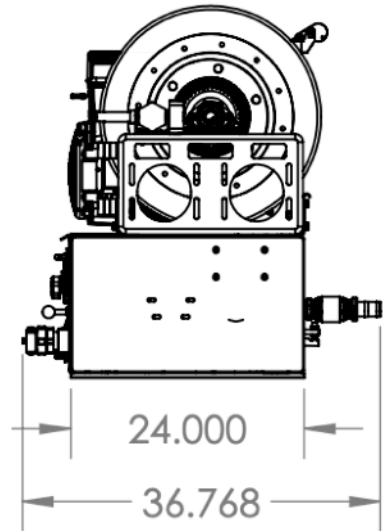
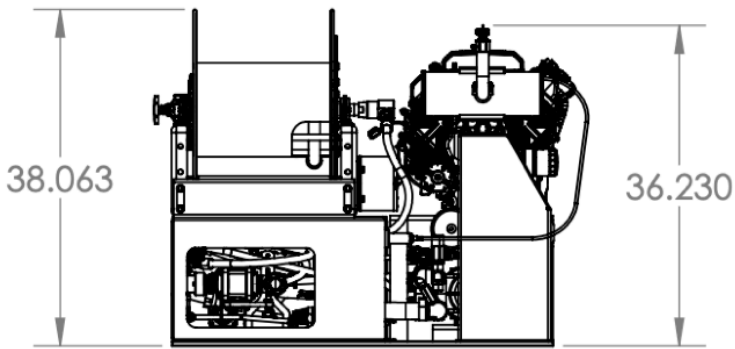
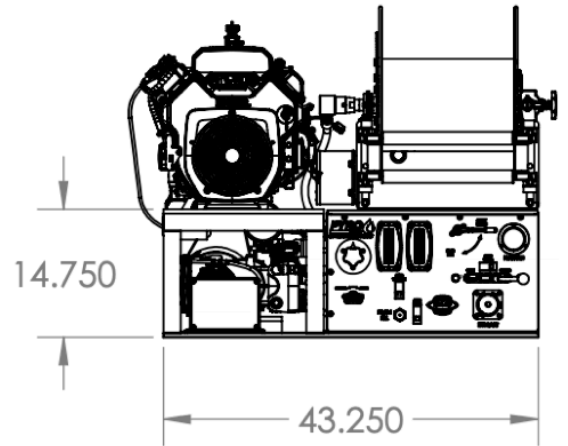
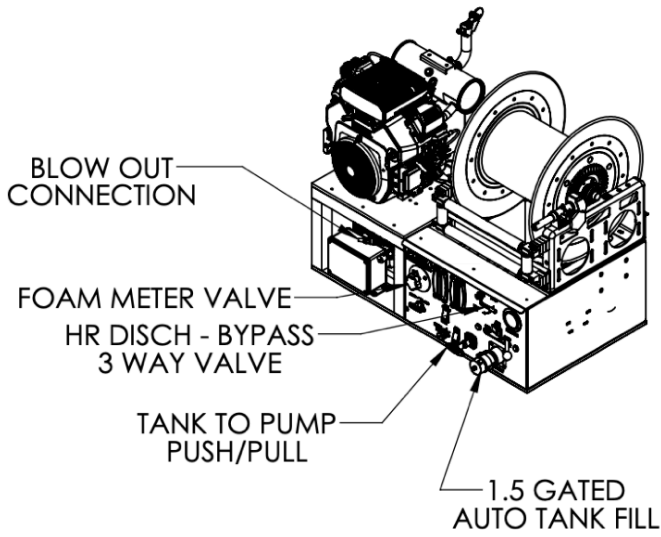

Diesel Option