

## Chemical Mix, Containment & Recovery System For Turf Care Facility - Chemical Mix/Load/Storage Areas



**The Chemical Mix, Containment and Recovery System** by ESD allows you to transform your chemical area so that you can safely and effectively mix and load your turf care chemicals in a single contained area. In the event of a chemical spill, the chemical solution will be contained in the Chemical Sump and can be recovered with the Chemical Recovery Tank for reuse or proper disposal. The Chemical Sink drains to the Chemical Sump as well, to complete the containment process. All three products are constructed of marine-grade aluminum for maximum durability and chemical resistance.

### Specifications:

#### Chemical Recovery Tank:

<b>Approximate Dimensions</b>	35"L x 46 1/2"W x 55" H
<b>Tank Capacity</b>	148 gallons
<b>Filtration</b>	100 microns
<b>Utility Requirement</b>	20-100 psi compressed air for air-powered diaphragm pump, 1/4" air inlet

#### Chemical Sump:

<b>Approximate Dimensions</b>	30½"L x 30½"W x 26" H
<b>Cover Screen</b>	20 gauge perforated Stainless Steel

#### Chemical Sink:

<b>Approximate Dimensions</b>	78 3/16" L x 25 1/16" W x 51" H
<b>Utility Requirement</b>	3/4" fresh or irrigation water

#### Chemical Fill Hose & Hanger:

<b>Hose Specification</b>	1 1/2" diameter, 25' long
<b>Utility Requirement</b>	1 1/2" fresh or irrigation water



## Chemical Mix, Containment and Recovery System

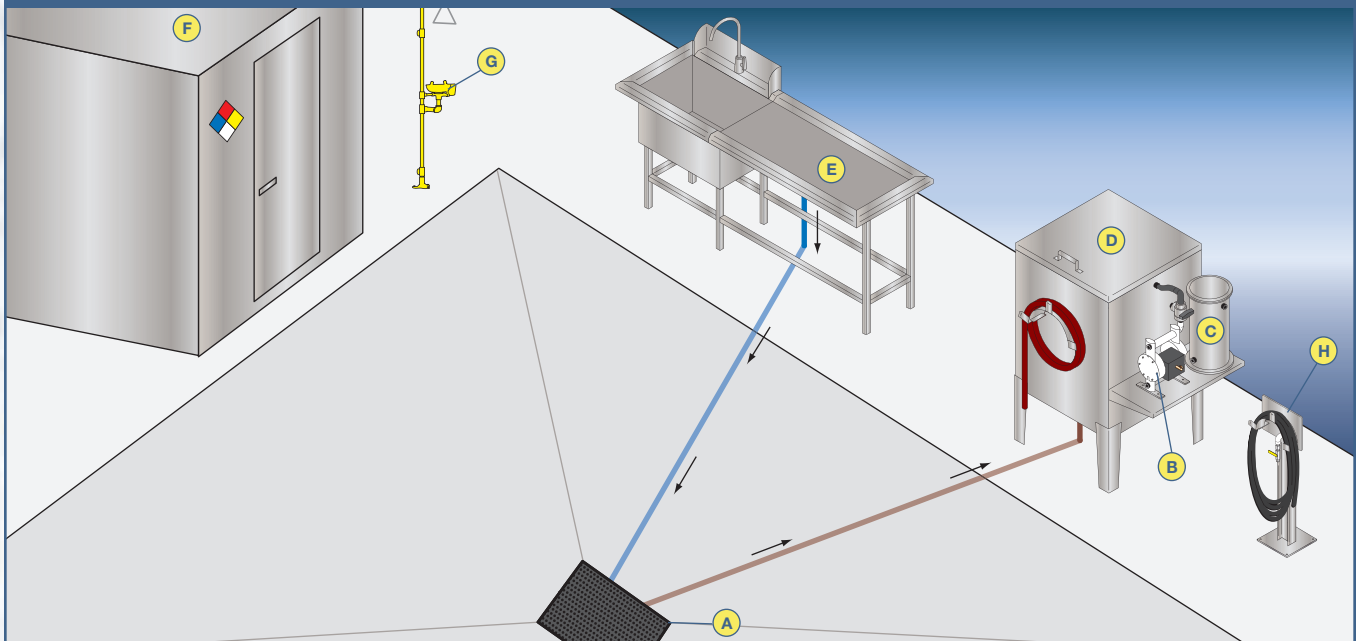

### **A** Chemical Containment Sump.

Potential chemical spills are captured by the Chemical Containment Sump. The sump has a perforated stainless steel cover to strain out unwanted debris such as twigs, leaves and pebbles. The V-bottom of the sump allows for nearly 100% evacuation, and recapture, of liquids from the sump.

### **B** Air-Actuated Pump.

Located on the Chemical Recovery Tank is an Air-Actuated Pump. When activated by manually turning on the air control valve, the pump will draw solution from the Chemical Containment Sump. The pump is constructed of polypropylene with a Viton® diaphragm for maximum chemical resistance and longevity. The pump may also be run dry for periods of time without sustaining damage.

### **C** Filter.

The air pump suctions the liquid through a reusable 100 micron poly bag filter to remove fine particulates from the waste stream. The filtration allows the liquid to be pumped into the spray rig for proper disposal without clogging the chemical sprayer's nozzles. The filter can also prepare a chemical spill for recovery and reuse.

### **D** Chemical Recovery Tank.

The filtered chemical solution can be pumped to the inside of the 148 gallon Chemical Recovery Tank for storage. Alternatively, with the twist of a valve, the solution can be directed to the hose on the front of the tank, and can be pumped into a spray rig, spray tank, or chemical container.

### **E** Chemical Sink.

The 4 foot long counter of the ESD Chemical Sink makes it a handy tool for handling and premixing chemicals. The goose-neck faucet allows for a 5-gallon bucket to be placed and filled directly in the sink. Any drainage from the sink flows to, and is captured in, the Chemical Containment Sump for appropriate handling and disposal.

### **F** Chemical Storage Building.

Chemicals should be stored directly adjacent to the chemical mix/load area in an appropriately marked storage facility. An adjacent structure allows for complete containment from storage to use. A variety of sizes of Chemical Storage Buildings are available from ESD Waste2Water, Inc. Detailed specification sheets are available upon request.

### **G** Emergency Eye Wash/Shower Station.

No chemical area is complete without an Emergency Eye Wash / Shower Station. These are also available through ESD.

### **H** Fill Hose & Hose Hanger.

A 1½" Fill Hose is recommended for rapid filling of spray rigs. ESD supplies both the Fill Hose and the Hose Hanger.

**Custom Design.** ESD offers free design assistance for your chemical area, adding our experience to your specific needs. Detailed designs available in both PDF and DWG formats.

**Option: Rapid Chemical Mix Station.** The Chemical Recovery Tank can be replaced by a ESD Rapid Chemical Mix Station. When you need to mix chemicals quickly and efficiently to "stay ahead of play", the Rapid Chemical Recovery Station is an effective solution. Detailed specifications are available from ESD Waste2Water, Inc.

